



User-Friendly Basic Low-Profile Scales for General Shipping and Veterinary Applications

The Courier 3000 Series shipping scales' intuitive, user-friendly interfaces, bright displays, and low-profile steel construction ensure durability and reliability from offices to warehouses to even veterinary offices (the Courier 3000 is effective for weighing small animals). Versatile and effective.

Unique Features:

- Ideal for general shipping jobs or veterinary applications. Low-profile design with 1.5 mm thick painted steel platform to last rigorous daily use. Coiled cable ensures flexible display mounting.
- The Courier 3000's Display Hold mode (for use with large boxes and packages) retains weight on the large 28 mm high backlight display, until cleared.
- AC adapter power included, and disposable battery power (not included) for portable use.

COURIER™ 3000 Shipping Scales

Specifications

Model	i-C31M35R	i-C31M75R	i-C31M200R	i-C31M75L	i-C31M200L
Capacity x Default Readability	35 kg x 0.02 kg	75 kg x 0.05 kg	200 kg x 0.1 kg	75 kg x 0.05 kg	200 kg x 0.1 kg
Maximum Displayed Resolution	1:1 750	1:1 500	1:2 000	1:1 500	1:2 000
Weighing Units	kg, lb				
Application Mode	Weighing, Display Hold				
Display	28 mm digit height, 4-digit, 7-segment LCD with white backlight				
Keyboard	2 mechanical function keys				
Construction	ABS Plastic Indicator Housing Painted steel base - L models with smooth platform, R models with raised, embossed tread				
Cable length	2 m (full extension)				
Stabilization Time	1 second				
Power	AC Power adapter: 100-240VAC ~ 0.5A 50/60Hz; Power output: 5.0 VDC 1.0 A (included) or Dry cell battery: 3 x AA (LR6) Batteries (not included) Battery life: 100 hours continuous use with backlight off				
Operating Temperature Range	-10 °C to 40 °C				
Safe Overload Capacity	150% of capacity				
Platform Dimensions (L x W x H)	329 x 319 x 43.5 mm			520 x 400 x 52.9 mm	
Net Weight	2.7 kg			8 kg	
Shipping Weight	3.4 kg			9 kg	
Shipping Dimensions	395 x 385 x 155 mm			600 x 485 x 100 mm	

Outline Dimensions

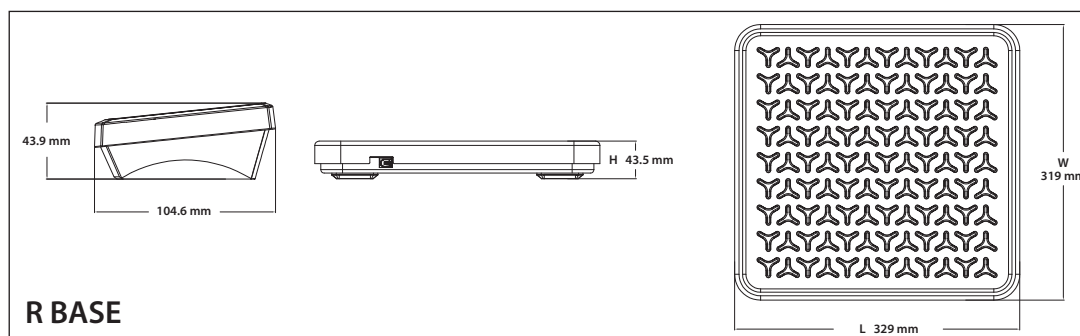
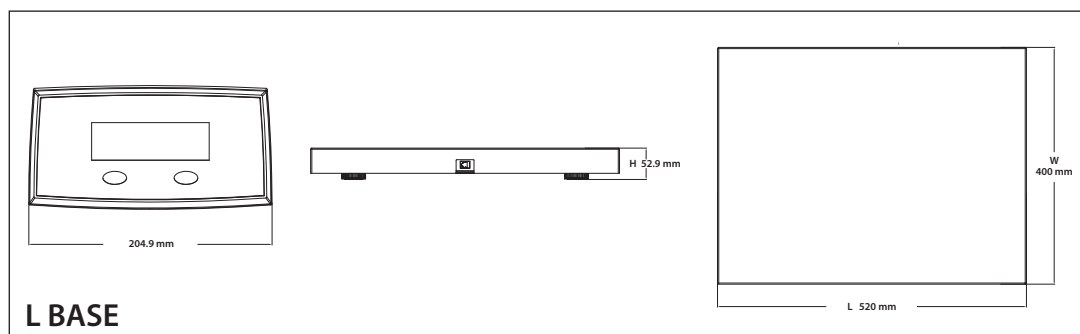

Compliance

- **Product Safety:** IEC/EN 61010-1; UL certified power supply
- **Electromagnetic Compatibility:** IEC/EN 61326-1 Class B, basic environments; FCC Part 15 Class A;
Canada ICES-003 Class A
- **Compliance Marks:** CE, UKCA
- **Other:** WEEE, RoHS

Accessories

Spiral cable connection base to indicator 9m max i-C51 i-C31.....30809920

ODECA S.R.L.

INDUSTRIAL WEIGHING SYSTEMS
Via dell'Industria, 20 - 21044 Cavarina (VA) - ITALY
Tel. +39 0331 219156 ; +39 0331 218844
fax: +39 0331 218366
email : info@odeca.it
http://www.odeca.it